

## ENERGION M | ODM 50 HYBRID LIGHT VERSIE

Buitenunit ODM (lucht/water warmtepomp)

met:

- Stille ventilator
- Buitenunit met hermetisch gesloten koudemiddelcircuit
- Energiezuinige circulatiepomp
- Automatische ontluchter
- Overstortventiel
- Kleppen en sensoren

Systeem		
Maximaal verwarmingsvermogen @A7W35	kW	7,65
COP @A7W35 *		5
Maximaal verwarmingsvermogen @A-7W35	kW	5,2
COP @A-7W35 *		2,9
Verwarmingsklasse @55°C (in range A+++ / D)		A++
Verwarmingsklasse @35°C (in range A+++ / D)		A+++
Buitenunit		50
Nominale stroom	A	13,5
Maximale stroom	A	14,3
Beveiliging	A	20-C
Nominale spanning	V	230
Grenswaarden	V	216-243
Cos phi		> 0,9
Voedingkabel (H07RN-F)		3G4
Elektrische voeding		1-fase
Gewicht	kg	66

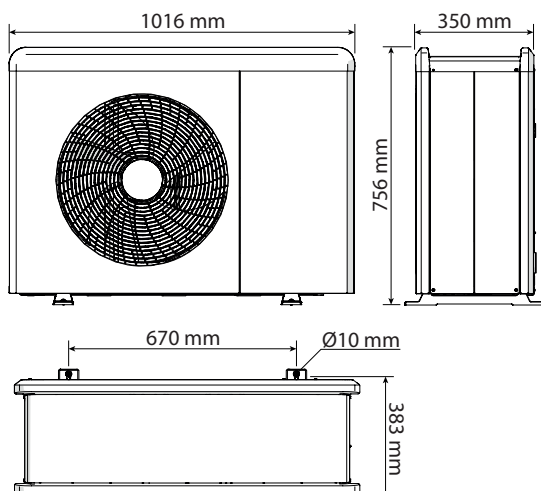

## ENERGION M HYBRID LIGHT



De kleine "M-Lightbox"-module is de basis

uitvoering van een ATAG ENERGION

Lucht/Water warmtepomp aansturing.

Deze Light uitvoering bevat geen hydraulische componenten en back-up verwarming.

## UITRUSTING

De "M-Lightbox"-module bestaat uit een module met het klemmenblok voor de elektrische aansluitingen en de NEOZ bedieningsinterface.

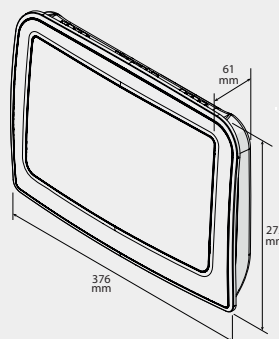

## SAMENSTELLING PAKKET

Energion M Hybrid Light 50

Buitenunit ODM 50 - Hybrid Light versie



Buffervat 25L



Lightbox controlbox



NEOZ bedieningsinterface



One Zone Wifi thermostaat, Zwart



Aanlegvoeler 10K



CV transportpomp

Wilco Yonos Pico 25/1-4-130



Geleverd op 1 pallet en omdoos Artnr: **ASETHL50**

